



DANISH
TECHNOLOGICAL
INSTITUTE

CONFERENCE

Application of CT Scanning in Industry

31st May 2011, 08.30-17.00
Danish Technological Institute
Gregersensvej 1, Conference Hall
DK-2630 Taastrup

Danish Technological **Institute**
Measurement and Quality

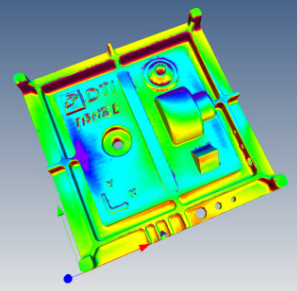

08.30-09.00	Registration and coffee	
09.00-09.15	Welcome to Danish Technological Institute	Maria Holmberg, DTI, DK
09.15-09.30	Introduction	Prof. Leonardo De Chiffre, DTU, DK
09.30-10.10	Improving the Production using X-Ray Computed Tomography - Potentials and Challenges	Prof. Robert Schmitt, RWTH Aachen University, Germany
10.10-10.40	Coffee Break	
10.40-11.00	Measuring micro features with dense point clouds – Scanning with tomography, micro-probes and laser	Detlef Ferger, Werth Messtechnik GmbH, Germany
11.00-11.20	Nano- and Microtomography for materials science	Bart Pauwels, SkyScan, Belgium
11.20-11.40	Industrial Computer Tomography and Precision	Christof Reinhart, Volume Graphics GmbH, Germany
11.40-12.00	Automating Analysis	Martin Vester- Christensen / Søren Erbou, Deformalyze ApS, Denmark
12.00-13.00	Lunch	

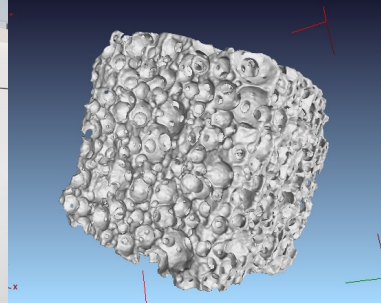
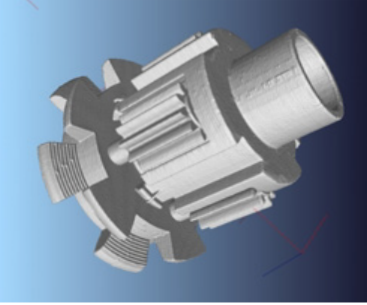

13.00-13.20	Aspects of traceability of dimensional CT measurements	Dr. Markus Bartscher PTB, Germany
13.20-13.40	International round robin on dimensional computed tomography	Dr. Simone Carmignato, Padova University, Italy
13.40-14.00	CT Metrology – CT Round Robin	Ph.d. student Jais Angel, DTU, Denmark
14.00-14.30	Coffee break	
14.30-14.50	Image Analysis for Volumetric Industrial Inspection and Interaction	Prof. Rasmus Larsen, DTU, Denmark
14.50-15.10	CT scanning strategy: Prediction of image quality	Post Doc Jochen Hiller, DTU, Denmark
15.10-15.30	Influence Parameters in CT scanning	Ph.d. student Pavel Müller, DTU, Denmark
15.30-16.00	Coffee Break	
16.00-16.20	Measurement of micro moulded parts by Computed Tomography	Dr. José A. Y. Fabra, University of Zaragoza, Spain
16.20-16.40	Accuracy in biology	Lars Bager Christensen, DMRI, Denmark
16.40-17.00	Closing and Summary	Maria Holmberg, DTI, Denmark

Published by Teknologisk Institut Måling og Kvalitet Gregersensvej 2630 Taastrup

Editor Maria Holmberg

Layout Susanne Gundlach

Registration for the conference must be done before 12th May 2011 at the link below:

<http://www.dti.dk//30509.1,1>

Everybody is welcome to bring a scientific or technical poster

Futher information:

Maria Holmberg

Measurement and Quality

Phone: (+45) 7220 3006

E-mail: mahg@teknologisk.dk