

Refrigeration in supermarkets

Historic insight

November 2017

Danfoss

ADVANSOR 
by HILL PHOENIX

Content

- Advansor's history in brief
- Natural refrigerants- the alternatives
- Historical system designs and why CO₂ had to win in the end!
- Developments and improvements on TC CO₂
 - Parallel compression
 - Ejectors
- Conclusions and questions

History

DKK 250 M
Turnover

Torben Hansen and Kim Christensen established Advansor in **2006**. It has since progressed rapidly in terms of technology and an over-all growth.

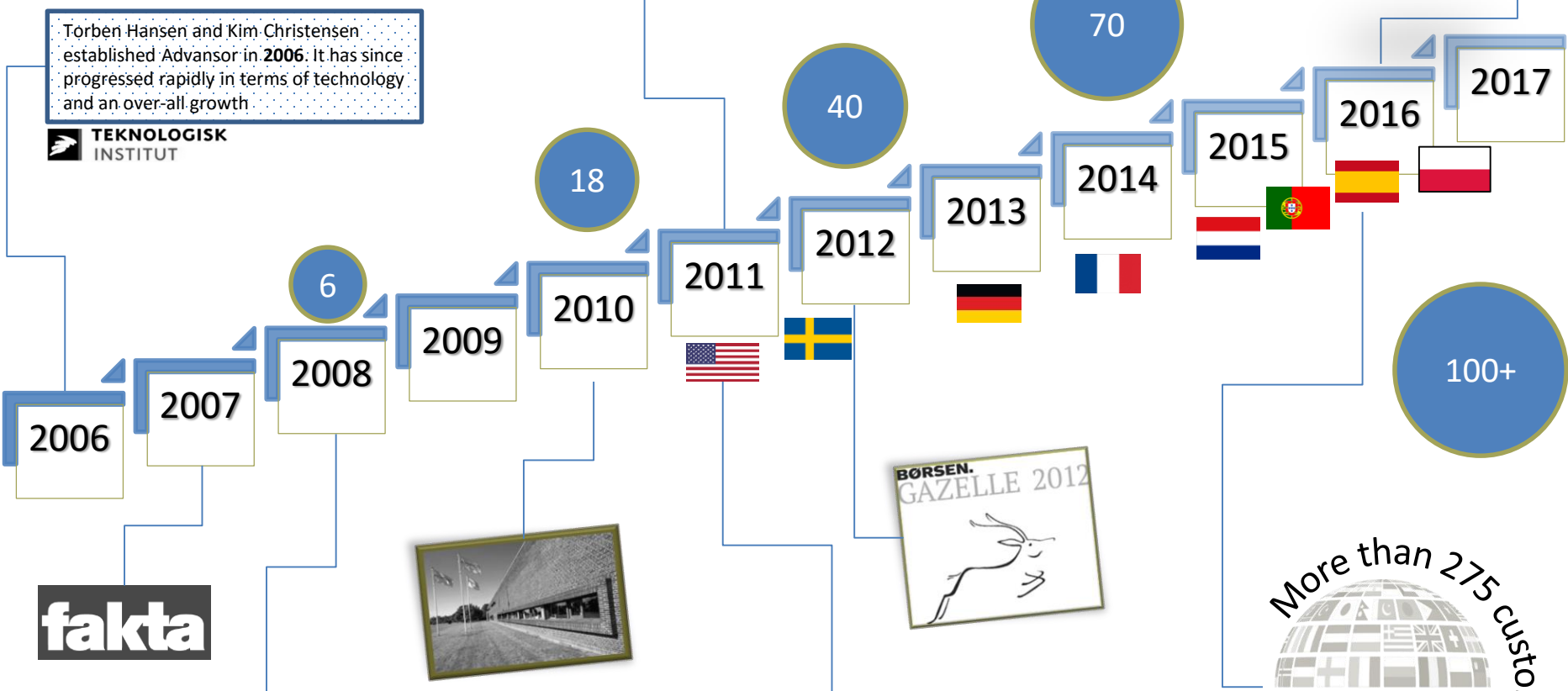

Advansor is sold to HillPhoenix, USA in **2011** but remains very "Danish" with its entrepreneurial roots and values

HillPhoenix.

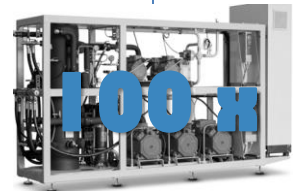

The history “Ozone depletion” and “Green House effect”

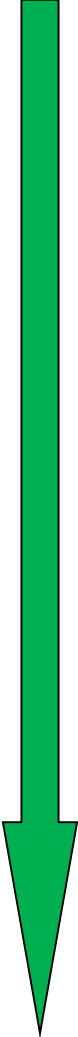
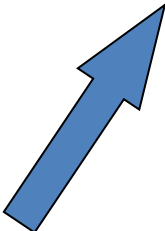
- 
- 
- 1834: Perkins mechanical vapour compression refrigeration with ethyl ether
 - 1880s ammonia, sulphuric acid
to carbondioxide and propane
 - 1920s ...
 - 1930s CFCs (R12)
 - 1950s HCFCs (R22, R502)
 - 1974 Ozone depletion theory (Mario Molina and Sherwood Rowland)
 - 1987 Montreal Protocol (phase-out of CFCs and HCFCs)
 - 1992 UN Framework Convention on Climate Change (FCCC)
 - 1996 Gustav Lorentzen conference in DK
 - 1997 Kyoto Protocol (reduction of emissions of HFC, PFC, CO₂, SF₆, N₂O, CH₄)
 - 3rd millennium... which refrigerants to use in the long term?**
 - 2001 Taxation on HFC's in DK (and other countries)
 - 2007 10 kg ban introduced in DK
 - 2015 F-gas directive (phase-down + other instruments), HFC prices

The closed refrigerant cycle

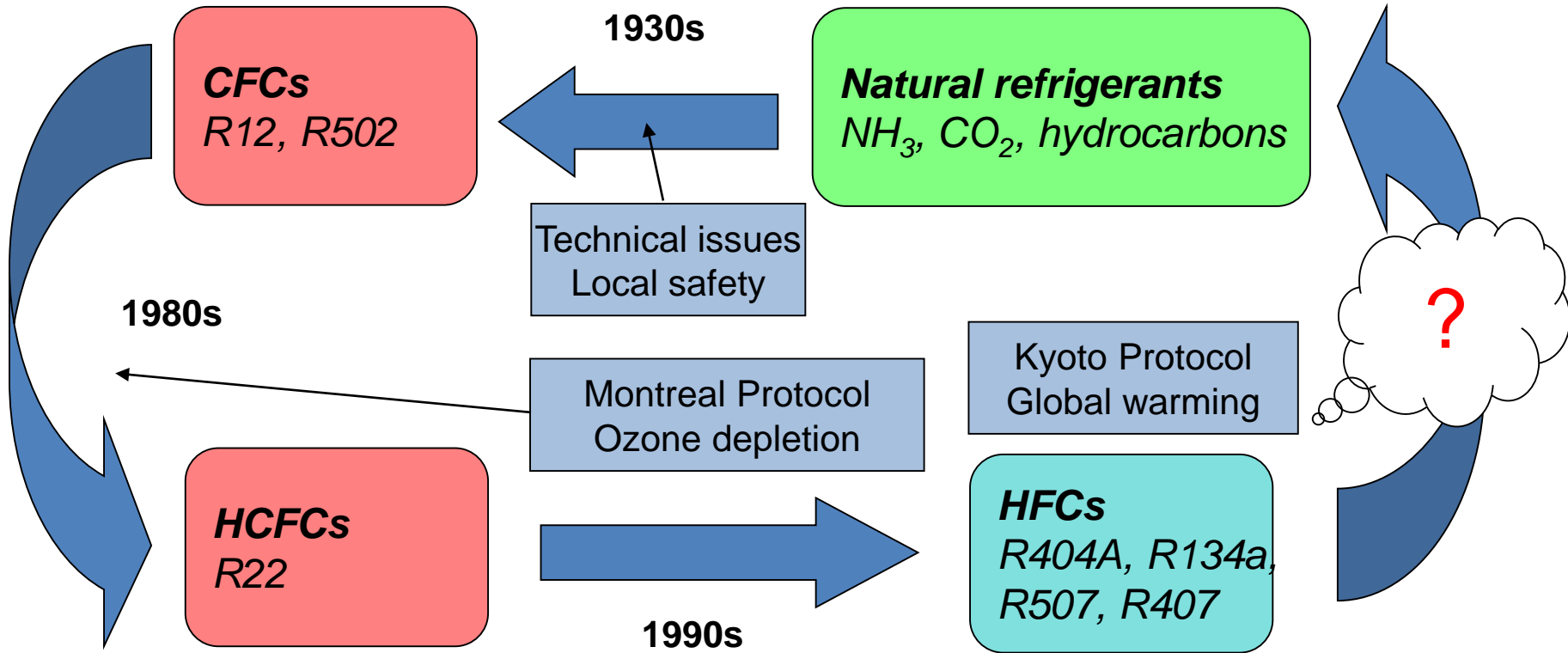

System configurations in supermarkets

HFC-anlæg

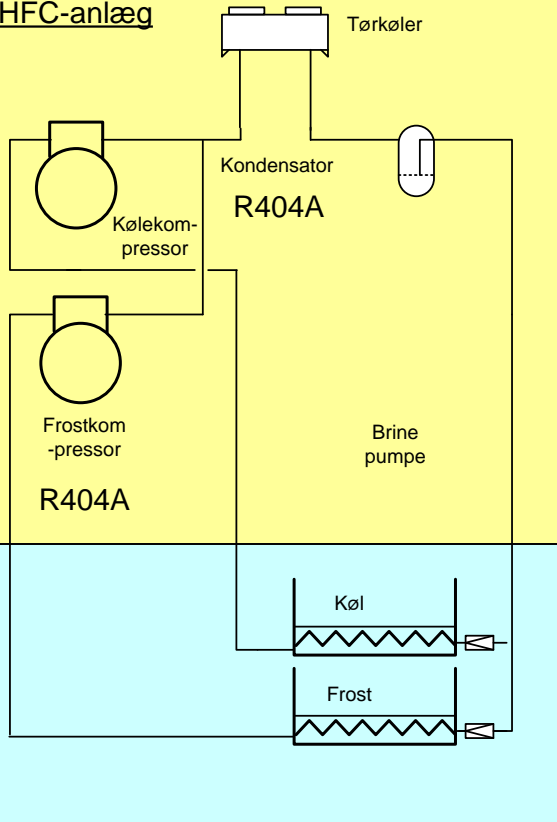

Kaskade-anlæg

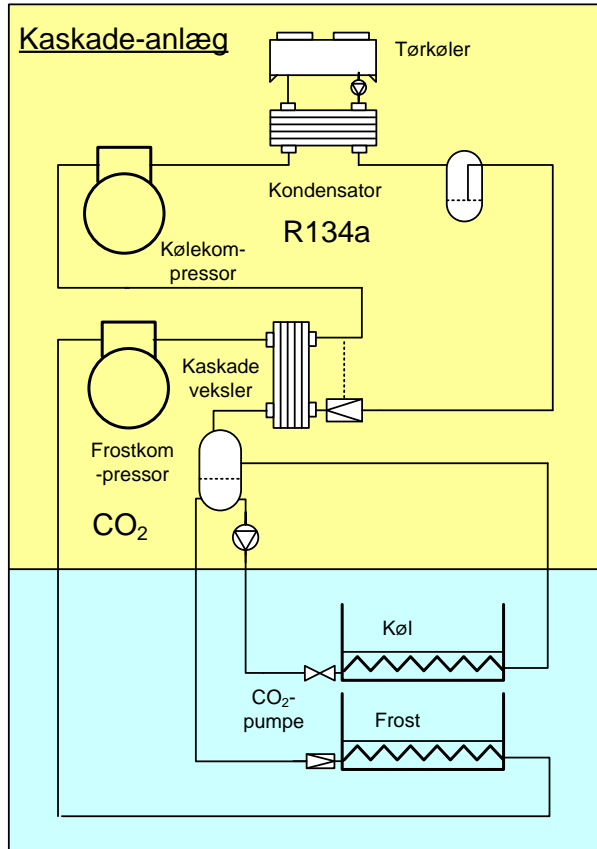

CO₂ anlæg

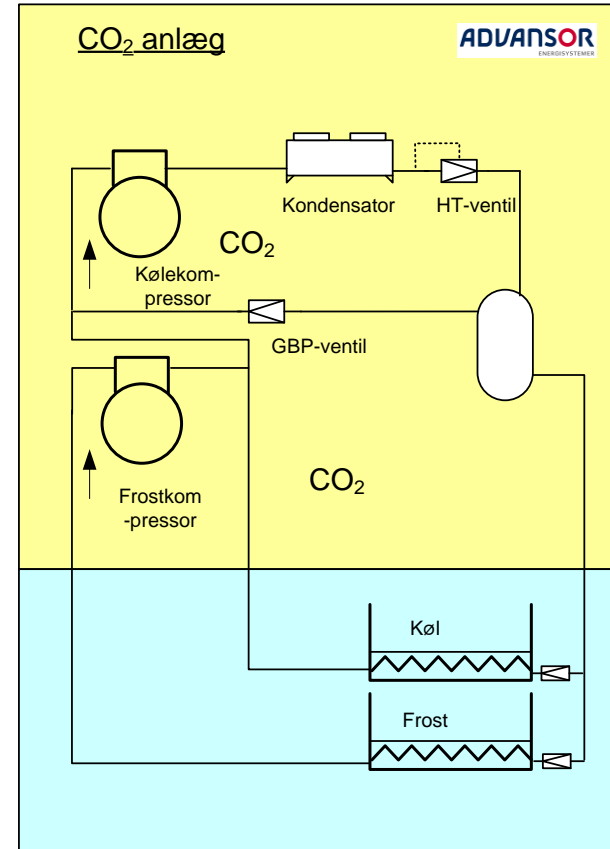

Possible refrigerants

- Hydro carbons

- ODP = 0, GWP < 8
- Non-toxic, but flammable
- Compatible, mixable, stabile
- Low density, low discharge temp
- High COP

- Ammonia

- ODP = 0, GWP = 0
- Toxic and flammable
- Corrosive, not mixable with oil
- Low density and high discharge temps
- High COP

- “New” refrigerants HFO’s

- Flammable (A2L?), toxic?, expensive

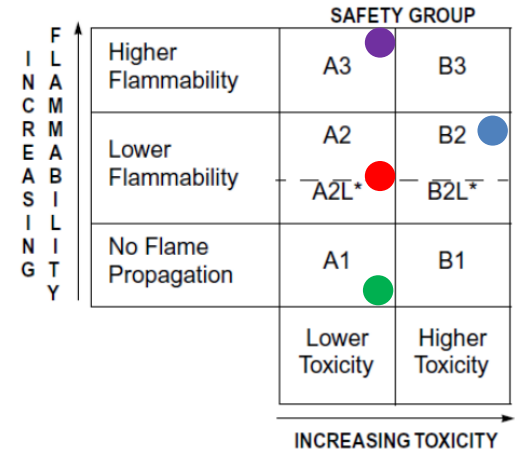

* A2L and B2L are lower flammability refrigerants with a maximum burning velocity of ≤ 3.9 in./s (10 cm/s).

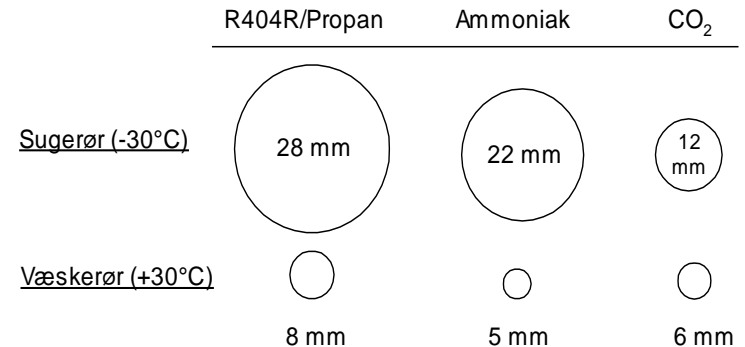

Accidents in a refrigerated warehouse - propane

- Aarhus, 2008
- Germany 2017

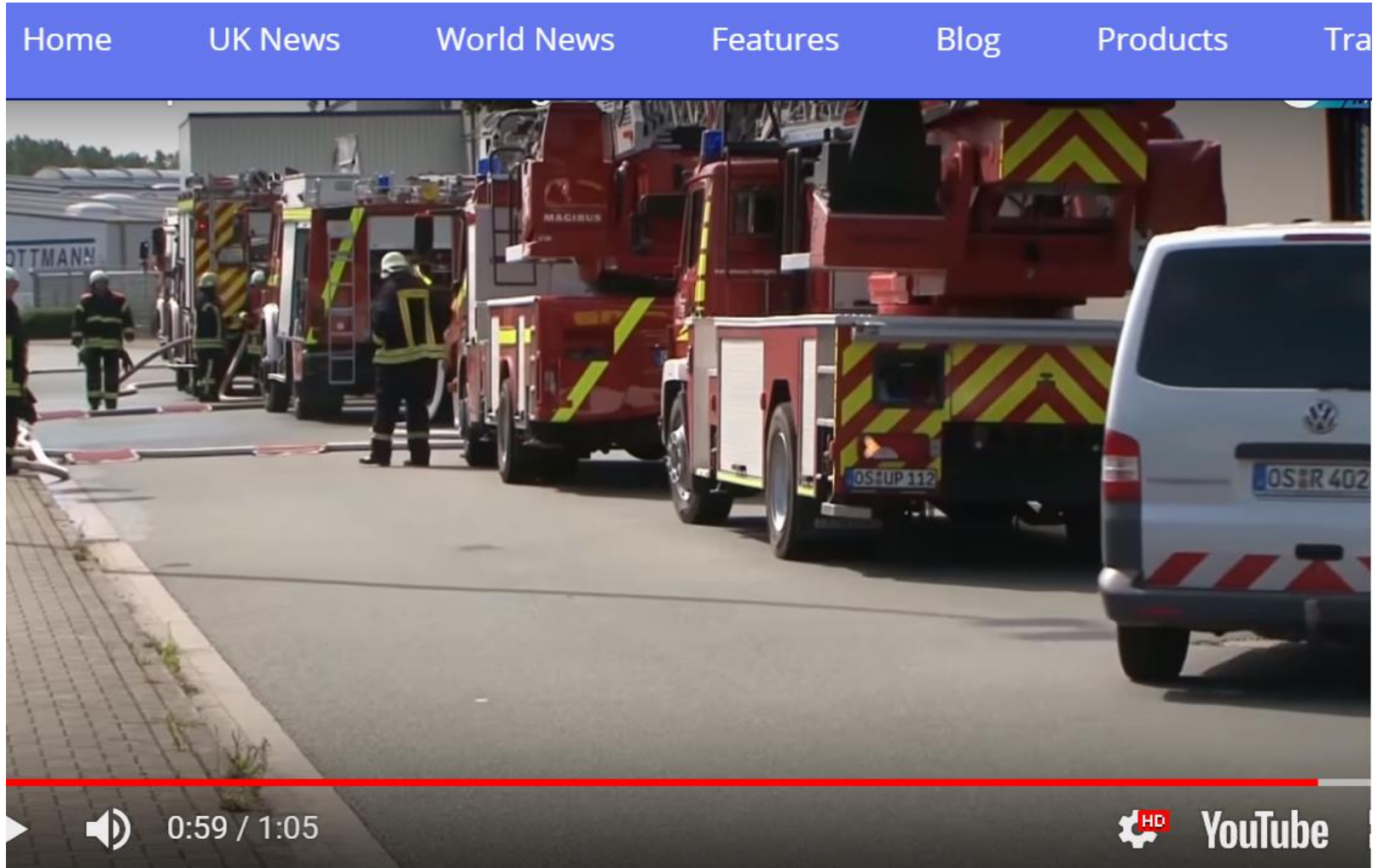

Supermarkets – 3-step rocket 1999-2005

Propane compressor



Brine pumps



Re

Supermarket rack development



Challenges with CO2

- High pressure
 - Knowhow and education
 - Understand the process
- How does it work?
 - More complex – 2 new valves
 - Centralized/ remote
- Electronic controls
 - EEV instead of TEV
 - Electronic controllers needed
- Warmer climates
 - New accelerating technologies
- Availability of components
 - Compressors 10-20 kW
- Price

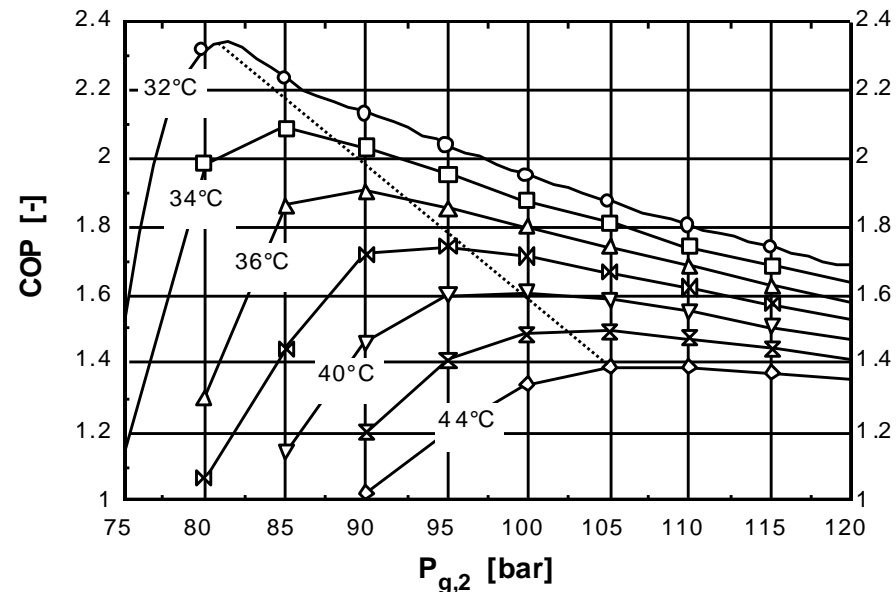



Challenges with CO2

- CO2 leaks
 - Knowhow and education
- High pressure - components
 - New accelerating technologies

%CO2	Symptoms
2 to 3	Shortness of breath, deep breathing
5	Breathing becomes heavy, sweating, pulse quickens
7.5	Headaches, dizziness, restlessness, breathlessness, increased heart rate and blood pressure, visual distortion
10	Impaired hearing, nausea, vomiting, loss of consciousness
30	Coma, convulsions, death

0,5% CO2 (=5000ppm) is normal gas detector set point

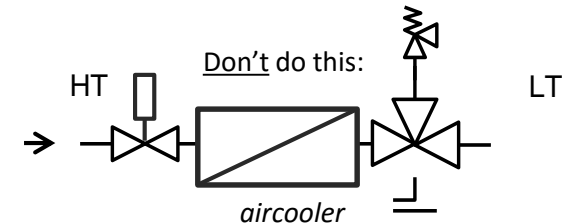

Tesco UK/ Migros Switzerland



Euroshop

through



Advantages of CO₂ as refrigerant

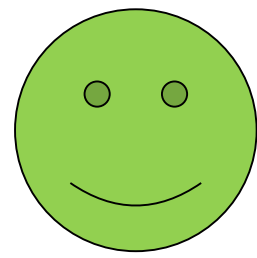

Green Profile
Future Proof

- **High level of security**
 - Safety valves and switches
 - Production and assembly approved
 - CE-labelled in accordance to PED cat. IV
 - High level of documentation

- **Reliable operation**
 - Well known tested components (compressors, exchanger, control)
 - Optimal and easy controls and monitoring
 - Resistant against compressor failure (oil handling, IHX, accu)
 - Secure handling of stand still pressure
 - High safety at service (pump-down, easy access)

- **Easy installation**
 - Only one refrigerant – CO₂ / DX and copper piping
 - Optimized design: copper, small pipes, hoses, and oil handling
 - No brine nor water pipes
 - Can be installed anywhere, no limits to the loc. of the condenser

- **Low installation and operating costs**
 - Low energy consumption
 - Low cost refrigerant
 - Easy and quick service
 - Availability of all components (standard)
 - 200% extra heat recovery
 - cooling with thermosyphon
 - Stable temperatures

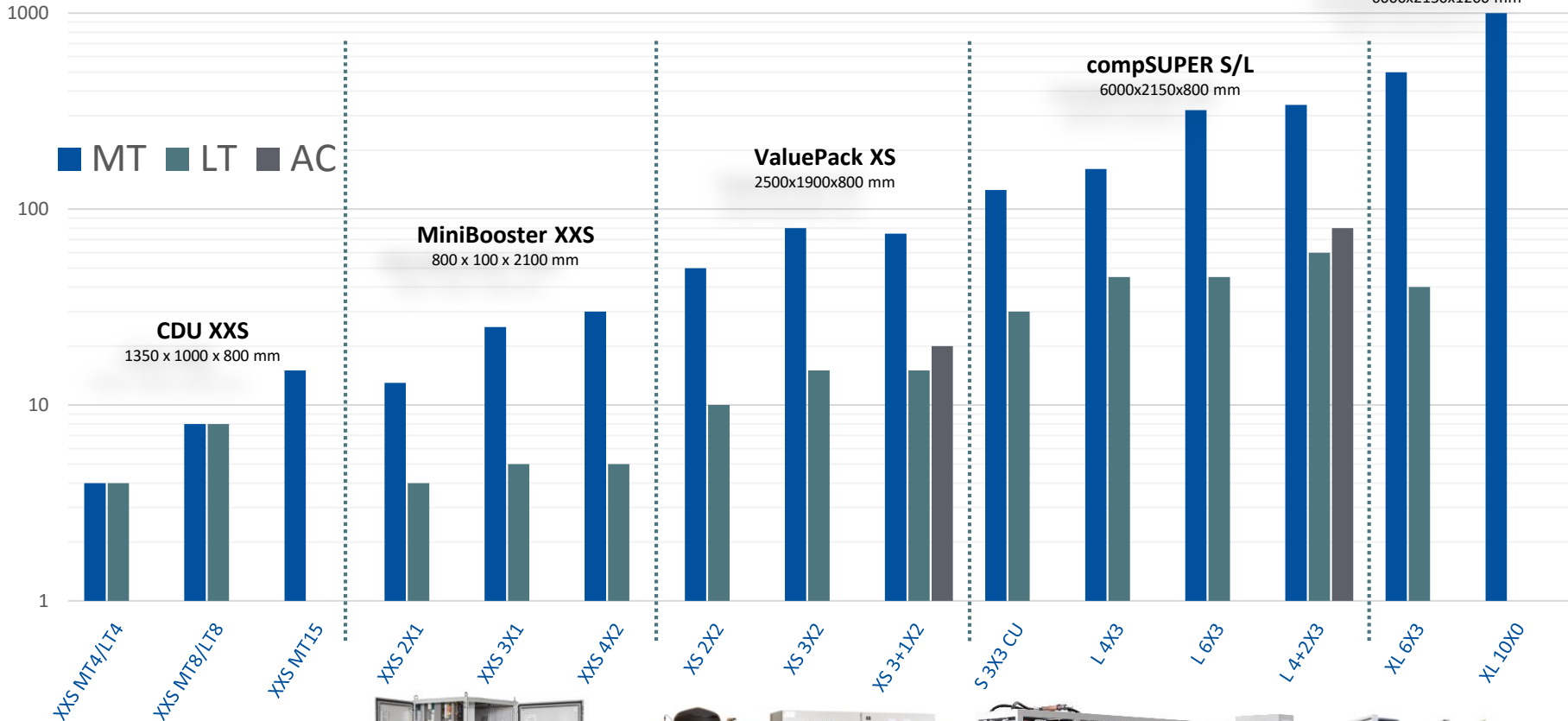

⊗ Small single weatherproof compressor unit

⊗ Retail/Pharmaceutical 5 evaporators



⊗ Small compact multi-compressor unit

⊗ Discount/Convenience



⊗ Medium multi-compressor unit

⊗ Supermarket/Convenience



⊗ Medium + Large multi-compressor unit

⊗ Supermarket/Hypermarkets



⊗ Large + XL multi-compressor unit

⊗ Industrial

Growth – Pricing and rack efficiency improvement over time

Overall, TC CO2 technology have improved its competitiveness

- Prices per kW have been reduced by more than 30% since 2006
- Energy efficiency has been improved by 25% since 2006

Pressure on price and technology

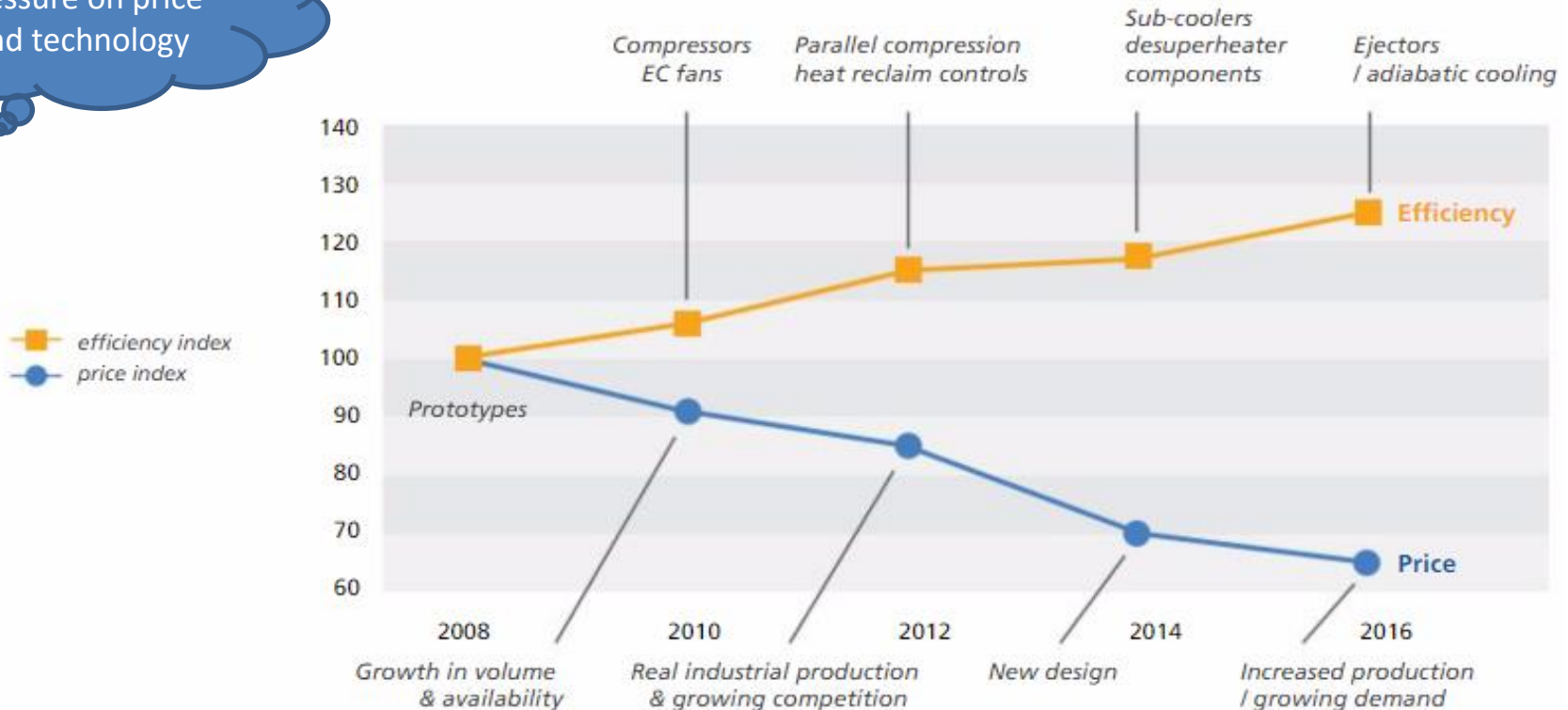

Source: Advansor, ATMOSphere Europe 2016

CO₂ evolution – Advansor solutions

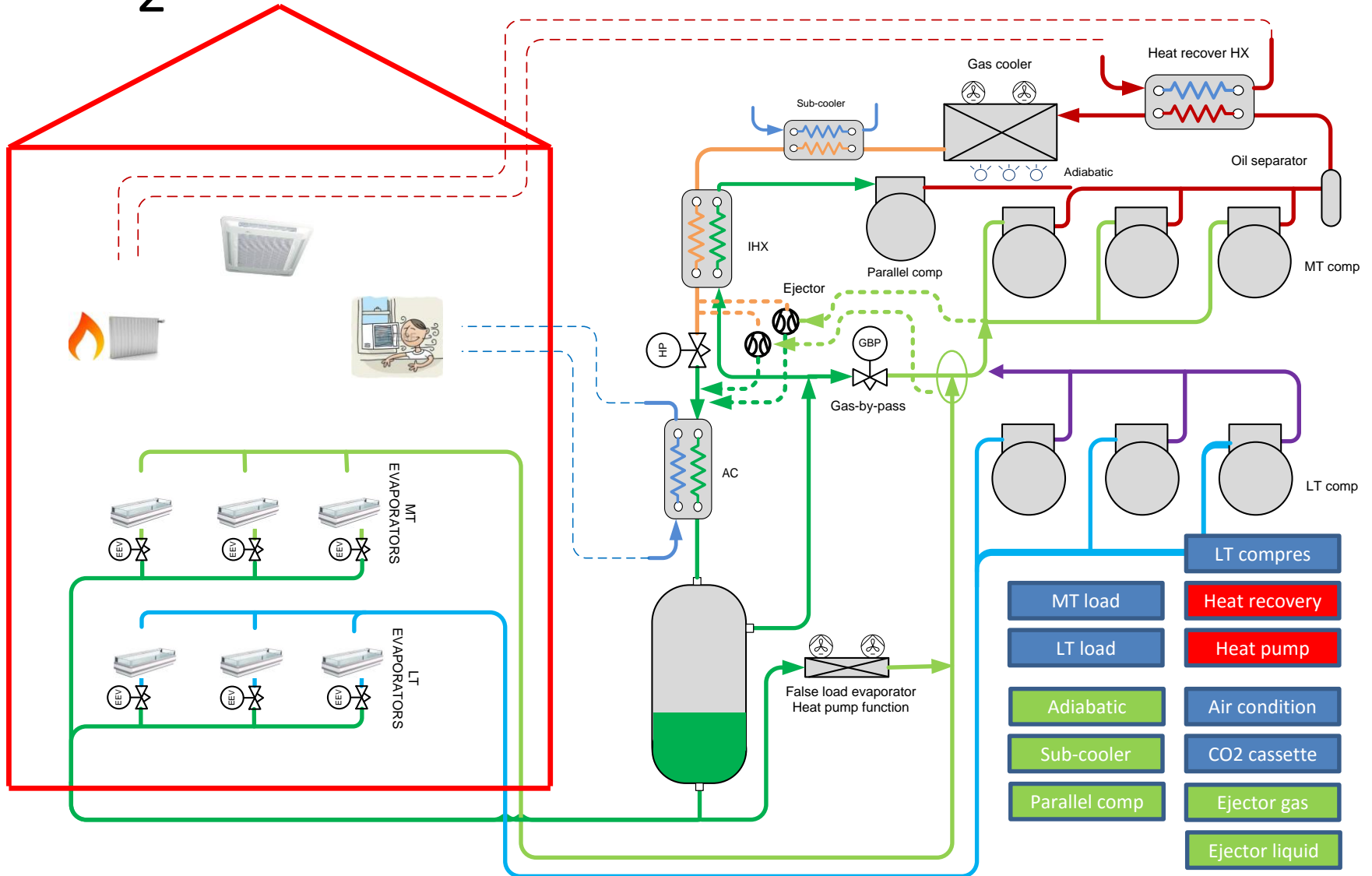

Energy and hot climate tech

Parallel compression, adiabatic, sub-cooling, ejector

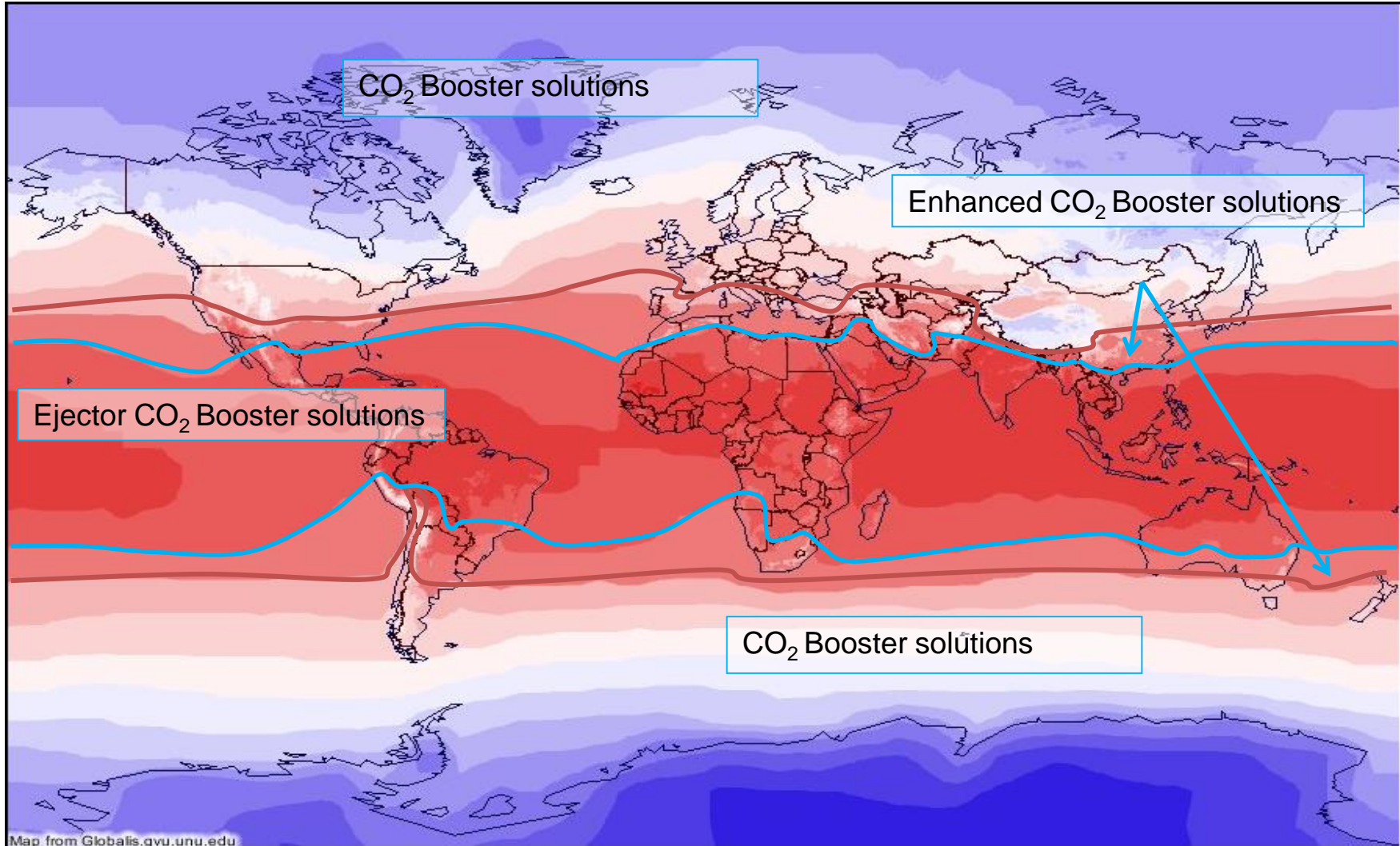

Big growth in the market for CO₂

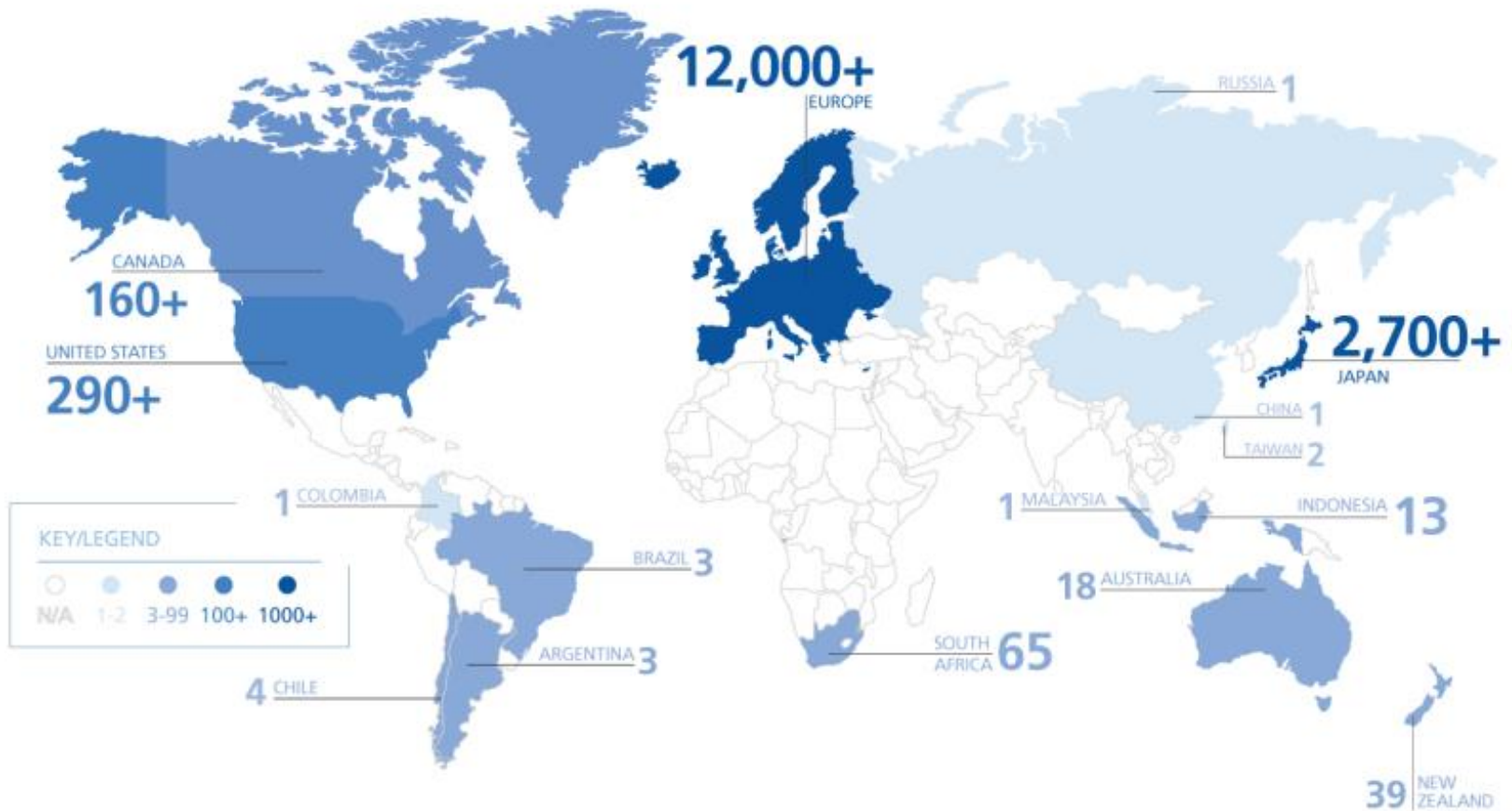

Reference: Shecco

Trends in Supermarkets

- Consumer/ shopper do change behavior!
- Digitalization: Robots, sensors, amusement
- Trends
 - Online shopping
 - Small store locally
 - Eat out!
- Physical store or on-line?
 - E-tail/ online shopping
 - Local collect
 - Cash & Carry / Drive Thru
 - Employee free stores

